

Research article

Mitochondrial DNA haplotype diversity and origin of captive sand tiger sharks (*Carcharias taurus*)

Robert Wynne^{†*}, Craig S. Wilding

School of Natural Sciences and Psychology, Liverpool John Moores University, Byrom Street, Liverpool, L3 3AF, UK

[†]Present address: School of Biological, Earth and Environmental Sciences, University College Cork, Distillery Field, North Mall, Cork, Ireland

*Correspondence: Robert Wynne; robert.wynne@ucc.ie; +353 83 039 1482.

Keywords: *Carcharias taurus*, captive populations, genetic diversity, haplotype, sand tiger shark

Article history:

Received: 20 Nov 2017

Accepted: 13 Jun 2018

Published online: 31 Jul 2018

Abstract

The sand tiger shark (*Carcharias taurus*) is listed as globally vulnerable by the International Union for Conservation of Nature (IUCN) with geographically isolated and separated global populations with little or no gene flow between them. Captive-breeding of these sharks in aquaria would reduce the need to populate displays with wild-caught individuals; however, sand tigers are notoriously difficult to breed in captivity. In this study we analysed 520bp of the mitochondrial D-loop to assess the haplotype diversity of 19 captive sand tiger sharks from aquaria in the UK and US. Genetic material was sampled in a non-invasive fashion through DNA extracted from shed teeth. Data obtained were compared to known, geographically mapped wild haplotypes to establish whether individuals from different global populations are being housed together. Results identified the haplotype of a minimum of 10 of the 19 sharks, detecting four different haplotypes, and identifying a previously undescribed haplotype (haplotype K). A major genetic subdivision between the haplotypes of the North West Atlantic and those of other global populations has been previously shown from population genetic analyses. Our results indicate that captive sharks can be from either side of this subdivision and occasionally these can be co-housed in the same aquarium. Since sharks with highly divergent genetic ancestry are being kept together, these findings have implications for conservation efforts regarding the individual needs of sand tiger shark populations and for captive-breeding program success rates.

Introduction

Anthropogenic impacts are thought to be a primary factor in the global depletion of shark populations (Myers et al. 2007; Barreto et al. 2015). This rapid decline has heightened awareness of the need to increase knowledge of evolutionary history, ecological interactions, and other fundamental aspects of shark biology. Sharks play a vital role in marine ecosystems: as the most diverse group of large predatory animals, many shark species have a key role in structuring different ecosystems and food webs (Baum 2003). Numerous shark species are facing potential extinction due to unsustainable fishing practices that harvest fins for commercial sale (Dulvy et al. 2008). These practices, combined with low genetic variability, specific habitat requirements, and life history traits such as low fecundity, late onset of sexual maturity, and slow

growth, make sharks particularly vulnerable to exploitation and the effects of environmental change (Stow et al. 2006; Ahonen et al. 2009). Sand tiger sharks (*Carcharias taurus*) are littoral dwelling, found in temperate waters (Compagno 2005) and due to their behaviour and biology, are geographically isolated and have globally disrupted populations (Ahonen and Stow 2008). Sand tiger sharks are identified as a globally vulnerable species by the International Union for the Conservation of Nature (IUCN.org, 2016), are listed as critically endangered in Australian waters, and are locally extinct in the Mediterranean (Stow et al. 2006).

Numerous studies on this species have investigated the pattern of genetic variation caused by the long-term isolation of these populations, demonstrating that extant populations have little or no gene flow between them (Stow et al. 2006; Feldheim et al. 2007; Ahonen and Stow 2008; Ahonen et al. 2009; Chapman et al. 2013). During genetic analysis,

mitochondrial DNA (mtDNA) is often favoured over nuclear DNA due to its ease of use, the availability of primers and relatively high mutation rates (Klimley et al. 1992). The hypervariable region of the D-loop and the CO1 gene are particularly targeted when studying sharks (Vélez-Zuazo and Agnarsson 2011) because sharks have a relatively low rate of molecular evolution (Martin 1995; Stow et al. 2006; Ahonen et al. 2009). However, mtDNA has its limitations, as it is non-recombining and maternally inherited, thus it can be misleading in certain phylogenetic studies which compare samples from related individuals (Griffiths et al. 2011).

Mitochondrial DNA analyses of wild sand tiger shark populations have identified 10 haplotypes: A, B, C, D, E, F, G, H, I and J, with some haplotypes unique to specific locations (Ahonen et al. 2009). For example, haplotypes F and G are unique to waters off the eastern coast of North America, haplotype J off the west coast of India, haplotype H in the western Pacific, and haplotype A off the coast of Southern Africa. Other haplotypes, such as B and D, have wider ranges and are found across the Atlantic Ocean, and the coasts of South America and Southern Africa (Ahonen et al. 2009). This geographic structure has also been confirmed in studies using nuclear DNA microsatellite markers which detect high levels of genetic differentiation between some populations. Ahonen et al. (2009) calculated F_{ST} values from microsatellite analyses of 0.324–0.699 between populations from the North West Atlantic and other populations. These values, coupled with mtDNA partitioning, led the authors to suggest that distinct populations should be treated as evolutionarily significant units (ESUs) for conservation purposes and that they be managed regionally (Ahonen et al. 2009).

If these geographically separated sand tiger shark populations are indeed true ESUs and if aquaria are housing individuals from different populations and attempting to breed them, the underlying high genetic differentiation between individuals may be hindering success. Thus, comparisons of genetic variability and haplotype structure between wild and captive populations of captive sand tiger sharks could give insight into why breeding programmes for captive sand tiger sharks are reported to have low success rates (Lucifora 2002).

Whilst some studies have collected muscle biopsies from live sharks or from animals that have been incidentally captured and subsequently died (Stow et al. 2006; Ahonen et al. 2009; Chang et al. 2015), non-invasive sampling is preferred. Their impressive size, distinctive dentation and ability to adapt to a captive environment make sand tiger sharks a popular choice for many public aquaria (Stow et al. 2006). This species is estimated to shed approximately one tooth per day (Correia 1999) making it possible to collect regularly shed teeth from the bottom of aquaria tanks as a source of DNA. Sampling from teeth is a nondestructive and non-distressing method of obtaining DNA (Ahonen and Stow 2008). Throughout this study shed teeth were collected in aquaria for DNA extraction and amplification; subsequently, haplotypes of captive sharks were compared to mtDNA haplotypes of wild individuals to determine where aquaria specimens were collected. If aquaria are found to be exhibiting individuals with different haplotypes, the facilities may be housing collections of sand tiger sharks from different regions and thus different ESUs.

Methods

Non-invasive sampling and DNA extraction

A total of 83 shed teeth of captive sand tiger sharks were received from five separate aquaria (Table 1) and DNA extraction was attempted on 36 teeth. Contributing aquaria housed varying numbers of animals (Table 1).

DNA was extracted from the dentine of teeth following the method of Ahonen and Stow (2008). Safeguards were put in place to reduce the likelihood of contamination during DNA extraction.

Table 1: Details of teeth samples obtained from each aquarium. Number of sharks housed at each aquarium, total teeth provided, and the number of teeth used for DNA extractions are indicated.

Aquarium	Number of sharks	Total number of teeth obtained	Number of teeth used
Blue Planet Aquarium	6	22	10
Disney	3	6	4
Dynasty Marine Associates	3	29	10
Aquarium of the Pacific	1	7	4
Georgia Aquarium	3	19	8

Teeth were drilled in a designated work area. Additionally, the electronic hand drill, clamps and vice were sterilised with 80% ethanol and 50% bleach solutions before and after each extraction.

A new 1 mm sterilised drill bit and disposable aluminum foil collection tray were used for each specimen. Each sample was fixed horizontally in a vice to ensure that the tooth powder fell directly into the foil collection tray. To reduce heat production during drilling, which may be detrimental to extraction success, teeth were drilled on a slow setting with a hand-held drill. Each tooth was drilled two to four times, and each hole was approximately 1.5 mm wide and 3 mm deep to obtain dentine powder from the root of the tooth. Following the methods of Ahonen and Stow (2008), dentine powder from each sample was weighed to ensure sufficient quantities were obtained for successful DNA extraction (approx. 0.02–0.06 g). The aluminum foil collection tray was manipulated into a funnel to carefully transfer the dentine powder into a 1.5 ml microfuge tube. After each tooth drilling, all materials used in the process (drill bit, collection tray, latex gloves and paper below the hand drill) were discarded and replaced, and the work areas decontaminated as outlined previously.

Haplotype	Nucleotide Position															
	4	1	1	3	3	3	3	3	4	4	4	4	4	4	4	4
HAP A	T	C	A	C	A	G	G	G	T	A	G	-	-	G	G	A
HAP B	A
HAP C	G	A
HAP D	A	A
HAP E	.	.	G	.	G	A	A	A
HAP F	.	.	G	T	G	A	A	A	.	G	A	A	T	A	-	-
HAP G	.	.	G	.	G	A	A	A	.	G	A	A	T	A	-	-
HAP H	.	T	G	.	G	A	A	A
HAP I	A	A
HAP J	A	.	.	C
HAP K	A	.	G	.	G	A	A	A	.	G	A	A	T	A	-	-

Figure 1: Genetic variability of sand tiger shark mtDNA haplotypes. Haplotypes are listed on the left column and nucleotide polymorphism positions are listed across the top row. The nucleotide at each position is given for haplotype A. Identical nucleotides to haplotype A are indicated with full stops (.) and deletions in the sequence are indicated as dashes (-). Accession numbers: Haps A–E=DQ250809-13; Haps F–J no accession (information retrieved from Table 1 of Ahonen et al. 2009). Hap K=MH229771. Note that over the 520bp studied, haplotype I (Ahonen et al. 2009) is indistinguishable from haplotype D.

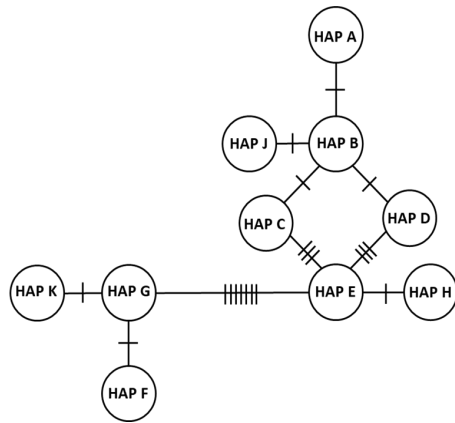

Figure 2: Haplotype network for partial mtDNA D-loop region of sand tiger sharks. Each hashed line indicates one mutational step between haplotypes.

DNA was extracted from the dentine powder using a DNeasy® Blood and Tissue kit (Qiagen). The manufacturer's recommended protocol (protocol B) was followed with the exception that only 20–50 µl of buffer AL was added to elute the DNA, depending on sample weight, with 50 µl buffer AL used for heavier samples (>0.05 g). Extracted DNA samples were incubated at room temperature for 1 min before being centrifuged for 1 min at 6000 x g.

Polymerase chain reaction

Polymerase chain reaction (PCR) was used to amplify ~550bp of the D-loop region of the mitochondrial genome using the primers of Stow et al. (2006). Amplification was conducted in 25 µl reactions containing 5 µl of DNA, 12.5 µl of master mix (Promega GoTaq HotStart), 0.5 µl of each primer (at 10 µM) and 6.5 µl of sterile water. Amplifications were performed with a Bio Rad T100™ Thermal Cycler with the thermocycling parameters described by Ahonen et al. (2009). Successful amplifications were purified using the Genejet™ PCR Purification Kit following the protocol provided and then sequenced using the Forward primer by GATC Biotech (Konstanz, Germany). Sequences were viewed, aligned and manually edited in CodonCode Aligner. The haplotype network of all available haplotypes was constructed using PopArt (Leigh and Bryant 2015).

Results

mtDNA genetic diversity

Of the 36 separate DNA extraction attempts, PCR was successful on 16 teeth (44.4% overall success rate). These figures are similar to those of Ahonen and Stow (2008). Following sequence editing, 520bp of the hypervariable D-loop region was identified from the 16 successful amplifications. Following the nomenclature of Ahonen and Stow (2008), four total haplotypes were revealed, namely B, F and G, and a new haplotype (K). These data were supplemented with the haplotypes identified by Ahonen et al. (2009) and Chang et al. (2015) (here labelled haplotype J) resulting in 10 haplotypes defined by 16 polymorphic sites (Figures 1 and 2). The novel sand tiger shark haplotype (K) found in a sample from Georgia Aquarium differed by one mutational step from haplotype G.



Figure 3: Geographic distribution of nine of the 10* sand tiger shark mtDNA haplotypes. A west–east hemisphere division is indicated by the dotted line. *As haplotype K was acquired from an aquarium, its global origin is unknown though it is closely related to haplotypes F and G.

Since the teeth were shed directly into aquarium substrate, it was impossible to match samples with individual sharks. Additionally, when two or more teeth sampled from the same aquarium yielded the same haplotype it was not possible to know if this was due to re-sampling the same individual or the sharing of haplotypes by multiple individuals. However, the haplotypes of several individuals were definitively identified, including two of the six sharks from Blue Planet Aquarium, three of six from Georgia Aquarium, two of three from Dynasty Marine Associates and two of three from Disney (Table 2). Since multiple instances of the same haplotype were obtained from separate teeth (e.g. three instances of haplotype G from teeth collected at Georgia Aquarium) these numbers represent the minimum number of individuals housed together.

Sand tiger shark mtDNA biogeography and the origin of captive sharks

Stow et al. (2006) and Ahonen et al. (2009) demonstrated geographic distribution of mitochondrial genetic diversity (Fig. 3). Five of the nine haplotypes shown in Figure 3 are unique to particular regions. Haplotype A is unique to South African waters and haplotype E is found only off the west coast of Australia. Haplotypes F and G are unique to the North West Atlantic, haplotype H is found only in Japanese waters, and haplotype J only in the waters off Abu Dhabi, United Arab Emirates (Chang et al. 2015). However, one haplotype (C), was shared across three Indo-Pacific regions: South Africa, western and eastern Australia. The notable division in the haplotypes found in the western and eastern hemispheres is also reflected in the haplotype network (Figure 2). Furthermore, the North Atlantic haplotypes (F and G) appeared isolated from the other haplotypes by seven polymorphic sites (Figures 2 and 3). Haplotypes F and G are found only in the western hemisphere and haplotypes A, C, E, H and J are found only in the eastern hemisphere. However, haplotypes B and D identified in Brazil were also found in South African waters.

The exact origin of captive sharks in public aquaria is often unknown. Table 2 and Figure 3 indicate the haplotypes of captive sand tiger sharks identified in this study and the sampling locations previously determined for haplotypes A–J (Ahonen et al. 2009; Chang et al. 2015). These data reveal that all captive shark

Table 2: Diversity and global distribution of mitochondrial haplotypes with number of individuals possessing that haplotype, and number of individuals from which the mitochondrial data was extracted ⁽ⁿ⁾.

Sample origin	n	Haplotypes ⁽ⁿ⁾
Blue Planet Aquarium	3	B ₂ , F ₁
Georgia Aquarium	6	G ₃ , F ₂ , K ₁
Dynasty Marine Associates	3	B ₁ , G ₂
Disney's Animals, Science and Environment	3	F ₁ , G ₂
Aquarium of the Pacific	1	G ₁
Secondary data	n	Haplotypes ⁽ⁿ⁾
Ahonen et al. (2009)	193	A ₃ , B ₄₀ , C ₈₆ , D ₃₄ , E ₇ , F ₇ , G ₅ , H ₉
-Eastern Australia	65	C ₆₅
-Western Australia	24	C ₁₇ , E ₇
-Japan	9	H ₉
-Brazil	6	B ₁ , D ₅
-South Africa	77	A ₃ , B ₃₉ , C ₄ , D ₂₉
-North West Atlantic	12	F ₇ , G ₅
Chang et al. (2015)	1	J ₁
-Abu Dhabi	1	J ₁

haplotypes are restricted to one of three regions: the southern Atlantic, south west Indian Ocean (haplotype B) and the North West Atlantic (haplotypes F and G). One shark with haplotype K (from Georgia Aquarium) has an unknown origin as it is a novel haplotype (Figure 1; Table 2). However, although novel, this haplotype is closely related to haplotypes G and F by one and two mutational steps, respectively (Figure 2).

The sharks from Disney, Georgia Aquarium and the Aquarium of the Pacific are all of haplotype F, G or K, indicating a North West Atlantic origin (Figure 3). However, these results indicate that sharks collected from different regions are housed together, with Dynasty Marine Associates housing together animals of haplotype B (southern Atlantic/south west Indian Ocean) and haplotype G (North West Atlantic), which are separated from each other by 11 mutational steps. Additionally, the Blue Planet Aquarium house ≥ 1 shark of haplotype B (from Brazil and/or South Africa) together with ≥ 1 shark of haplotype F (from the North West Atlantic), which are separated from each other by 12 mutational steps.

Discussion

This study assessed the haplotype diversity of captive populations of the globally vulnerable sand tiger shark through the analysis of mtDNA haplotypes. Sixteen successful PCR amplifications were achieved from 36 teeth, resulting in four haplotypes, one of which was previously undescribed (haplotype K). Of the 19 sharks potentially sampled, this study revealed the haplotypes of at least 10 of the individuals. Data from captive sharks were supplemented with data sets from Stow et al. (2006) and Ahonen et al. (2009), resulting in just 10 haplotypes from 219 individuals. Although there is a low number of haplotypes, and sand tiger sharks possess

a relatively low mutation rate (Stow et al. 2006; Ahonen and Stow 2008; Ahonen et al. 2009), there was a somewhat high number of polymorphic sites: 16 polymorphic sites within 10 haplotypes. A large proportion of these polymorphic sites separate two groups of haplotypes, supporting evidence of major genetic subdivisions in the global population of sand tiger sharks, also identified through microsatellite analyses (Ahonen et al. 2009). The results of the mtDNA analysis suggest a significant genetic subdivision between sand tiger shark populations given the low evolutionary rate of the species, and are further corroborated by the high F_{ST} estimates from microsatellite analyses (Ahonen et al. 2009). The low variability and low level of mtDNA variation found in sand tiger sharks are thought to be a result of both the life history traits and demographic events in the history of the species which may have caused sequential founder effects, followed by geographic isolation (Stow et al. 2006). These historical events could also provide an explanation for the hemispheric divide in haplotypes. Additionally, the Atlantic and Indo-Pacific Ocean populations are estimated to have been isolated for 3.5 million years (Coates and Obando 1996), which may explain why such a large genetic subdivision between the North West Atlantic haplotypes and those of other regions exist. Because sand tiger sharks are littoral, populations are often isolated by vast oceanic basins, and the temperatures and currents of these regions prevent inter-coastal movements for this species (Kohler et al. 1998; Ahonen et al. 2009). However, long-range movements of sand tiger sharks were documented by both Lucifora et al. (2002) and Dicken et al. (2006), and Otway and Ellis (2011) recorded individuals traveling over 1500 km off the coast of Australia.

Although one haplotype identified from the sequence data was novel, haplotype K, its origin can be speculated. Haplotype K differs from both haplotype F and G by 1–2 polymorphic sites and both these North West Atlantic haplotypes are segregated from other regional haplotypes by seven polymorphic sites. Since haplotypes F and G have a North West Atlantic origin, haplotype K is likely to have the same, although further samples of haplotype K need to be analysed to confirm this. However, Ahonen and Stow (2008) did not find this haplotype in 209 individual sharks analysed during their study.

The specific origins of captive sharks are often unknown since many aquaria acquire sharks from supply companies that provide only a general collection location. This can lead to ambiguity when attempting to determine the origin of individuals in captivity and may be a barrier to successful breeding. Here, we show that the origin of captive sharks can be determined from their haplotype, due to the strong geographic structuring of global sand tiger shark mtDNA haplotypes, to eliminate the ambiguity. These data inform upon the sharks' origins, and whether individuals from different wild populations are being displayed together in captivity. Of the four captive populations examined in this study, two institutes, The Blue Planet Aquarium and Dynasty Marine Associates, are potentially housing together individuals from different oceanic regions, possibly even different hemispheres. This may complicate the breeding capability of these individuals since there is evidence of a major genetic subdivision (Ahonen et al. 2009) that could act as a barrier to captive reproduction. Geographically isolated populations exhibit morphological differences, such as altered numbers of vertebrae and tooth rows, potentially due to genetic subdivision caused by the hemispheric isolation (Lucifora et al. 2003). These observable morphological changes could have implications for the ability of sharks from the different ESUs to interbreed. Other behavioural differences between divergent populations, such as courtship ritual changes or gametal changes, could also prevent mating. Henningsen et al. (2008) looked at the hormone cycles of captive sand tiger sharks and noted that the steroid patterns of housed individuals, although cyclical in

nature, were not synchronised. Such cycles may be population and region specific and be non-aligned in cases where animals are collected from distinct global populations. Differences in the pre- or post-zygotic barriers to reproduction between the separate ESUs of sand tiger sharks should be investigated to aid in captive reproduction efforts.

Further research into reproductive incompatibilities between disparate haplotype groups is clearly necessary and can assist collection management within aquaria and in the conservation of many other vulnerable shark species. Aquaria could then manage successful breeding programs with genetically compatible individuals which, in turn, could help build captive reserves of vulnerable species.

Although our sampling system was non-destructive, DNA extractions from shed teeth produced successful DNA extractions in fewer than 50% of extractions. Additionally, this method suffered from the problem that in aquaria housing multiple sharks, it was not possible to collect teeth from known individuals. Future work may address this through DNA extraction from non-invasively sampled mucus membranes on the skin or from inside the mouth (Lieber et al. 2013).

Conclusions

Sand tiger sharks rarely reproduce in captivity (<http://www.sezarc.org/sand-tiger-sharkreproduction>), which is a major problem for conservation efforts. Ahonen et al. (2009) demonstrated that genetic isolation of sand tiger shark populations has created genetically discrete entities in different regions. Furthermore, morphological, hormonal and behavioural differences have been reported between some populations. Whilst the available data does not yet imply the beginning of allopatric speciation, the deep genetic split between some sand tiger shark populations may create additional difficulties for captive reproduction efforts. Sand tiger shark conservation efforts would benefit from both additional genetic research to fully understand the extent of this split at the genomic level, and from further behavioural studies to understand how these genetic differences impact upon mating behaviour in the captive environment.

Acknowledgements

We would like to thank staff at the Blue Planet Aquarium, Forrest Young and the staff at Dynasty Marine Associates, Linda Penfold and SEZARC, the staff at Disney's Animals, Science and Environment, The Seas, Epcot®, Walt Disney World® Resort, Perry Hampton from the Aquarium of the Pacific and Chris Schreiber of Georgia Aquarium for the provision of shark teeth and Stefano Mariani and Judith Bakker (University of Salford) for the primers. The referee's helpful and constructive comments are gratefully acknowledged.

References

Ahonen H., Stow A. (2008) Shark jaws and teeth: an unexploited resource for population genetic studies. *Journal of Fish Biology* 73(2): 450-455.
 Ahonen H., Harcourt R., Stow A. (2009) Nuclear and mitochondrial DNA reveals isolation of imperilled grey nurse shark populations (*Carcharias taurus*). *Molecular Ecology* 18(21): 4409-4421.
 Barreto R., Ferretti F., Mills J., Amorim A., Andrade H., Worm B., Lessa, R. (2015) Trends in the exploitation of South Atlantic shark populations. *Conservation Biology* 30(4): 792-804.
 Baum J., Myers R.A., Kehler D.G., Worm B., Harley S.J., Doherty P.A. (2003) Collapse and conservation of shark populations in the Northwest Atlantic. *Science* 299(5605): 389-392.

Chang C., Jabado R., Lin Y., Shao K. (2015) The complete mitochondrial genome of the sand tiger shark, *Carcharias taurus* (Chondrichthyes, Odontaspidae). *Mitochondrial DNA* 26(5): 728-729.
 Chapman D., Wintner S., Abercrombie D., Ashe J., Bernard A., Shivji M., Feldheim, K. (2013) The behavioural and genetic mating system of the sand tiger shark, *Carcharias taurus*, an intrauterine cannibal. *Biology Letters* 9(3): 20130003.
 Coates A., Obando J. (1996) *Evolution & Environment in Tropical America*. Chicago: University of Chicago Press. 436pp.
 Compagno L. (2005) *Sharks of the World*. Princeton: Princeton University Press. 496pp.
 Correia J.P. (1999) Tooth loss rate from two captive sand tiger sharks (*Carcharias taurus*). *Zoo Biology* 18(4): 313-317.
 Dicken M., Smale M., Booth A. (2006) Spatial and seasonal distribution patterns of the raggedtooth shark *Carcharias taurus* along the coast of South Africa. *African Journal of Marine Science* 28(3-4): 603-616.
 Dulvy N., Baum J., Clarke S., Compagno L., Cortés E., Domingo A., Fordham S., Fowler S., Francis M., Gibson C., Martiñez J., Musick J., Soldo A., Stevens J., Valenti S. (2008) You can swim but you can't hide: the global status and conservation of oceanic pelagic sharks and rays. *Aquatic Conservation: Marine and Freshwater Ecosystems* 18(5): 459-482.
 Feldheim K., Stow A., Ahonen H., Chapman D., Shivji M., Peddemors V., Winter S. (2007) Polymorphic microsatellite markers for studies of the conservation and reproductive genetics of imperilled sand tiger sharks (*Carcharias taurus*). *Molecular Ecology Notes* 7(6): 1366-1368.
 Griffiths A.J.F., Gelbart W.M., Miller J.H., Lewontin R.C. (2011) *Modern Genetic Analysis*. New York: W.H. Freeman and Co.
 Henningsen A.D., Murru F.L., Rasmussen L.E., Whitaker B.R., Violetta G.C. (2008) Serum levels of reproductive steroid hormones in captive sand tiger sharks, *Carcharias taurus* (Rafinesque), and comments on their relation to sexual conflicts. *Fish Physiology and Biochemistry* 34(4): 437-446.
 IUCN.org (2016). IUCN - Home. [online] Available at: <http://www.iucn.org/> [Accessed 18 Feb. 2016].
 Klimley A., Anderson S., Pyle P., Henderson R. (1992) Spatiotemporal patterns of white shark (*Carcharodon carcharias*) predation at the South Farallon Islands, California. *Copeia* 1992(3): 680-690.
 Kohler N., Casey J., Turner P. (1998) NMFS cooperative shark tagging program, 1962-93: an atlas of shark tag and recapture data. *Marine Fisheries Review* 60(1): 1-87.
 Leigh J.W., Bryant D. (2015) PopART: Full-feature software for haplotype network construction. *Methods in Ecology and Evolution* 6: 1110-1116.
 Lieber L., Berrow S., Johnston E., Hall G., Hall J., Gubili C., Sims D.W., Jones C.S., Noble L.R. (2013) Mucus: aiding elasmobranch conservation through non-invasive genetic sampling. *Endangered Species Research* 1: 215-222.
 Lucifora L.O., Menni R.C., Escalante A.H. (2002) Reproductive ecology and abundance of the sand tiger shark, *Carcharias taurus*, from the southwestern Atlantic. *ICES Journal of Marine Science* 59(3): 553-561.
 Lucifora L., Cione A., Menni R., Escalante A. (2003) Tooth row counts, vicariance, and the distribution of the sand tiger shark *Carcharias taurus*. *Ecography* 26(5): 567-572.
 Martin A. (1995) Rates of mitochondrial DNA evolution in sharks are slow compared with mammals. *Nature* 357(6374): 153-155.
 Myers R., Baum J., Shepherd T., Powers S., Peterson C. (2007) Cascading effects of the loss of apex predatory sharks from a coastal ocean. *Science* 315(5820): 1846-1850.
 Otway N.M., Ellis M.T. (2011) Pop-up archival satellite tagging of *Carcharias taurus*: movements and depth/temperature-related use of south-eastern Australian waters. *Marine and Freshwater Research* 62: 607-620.
 Stow A., Zenger K., Briscoe D., Gillings M., Peddemors V., Otway N., Harcourt R. (2006) Isolation and genetic diversity of endangered grey nurse shark (*Carcharias taurus*) populations. *Biology Letters* 2(2): 308-311.
 Vélez-Zuazo X., Agnarsson I. (2011) Shark tales: A molecular species-level phylogeny of sharks (Selachimorpha, Chondrichthyes). *Molecular Phylogenetics and Evolution* 58(2): 207-217.